

BENCHMARK & CONTROL POINT

BENCHMARK & CONTROL POINT No. 1: MAGNETIC NAIL SET IN CONCRETE N: 656170.32 E: 2124597.15 ELEVATION = 678.58	BENCHMARK & CONTROL POINT No. 2: MAGNETIC NAIL SET IN CONCRETE N: 656013.25 E: 2124617.66 ELEVATION = 676.64
BENCHMARK & CONTROL POINT No. 3: MAGNETIC NAIL N: 656426.31 E: 2124644.57 ELEVATION = 677.04	BENCHMARK & CONTROL POINT No. 4: PIN FOUND N: 656239.07 E: 2124585.49 ELEVATION = 681.22

DATUM:
OHIO STATE PLANE COORDINATE SYSTEM
NORTH ZONE (3401)
HORIZONTAL DATUM: NAD 1983
VERTICAL DATUM: NAVD 1988

SURVEY NOTE:
A BOUNDARY SURVEY PURSUANT TO CHAPTER 4733-37 OF THE OHIO ADMINISTRATIVE CODE HAS NOT BEEN PERFORMED BY BRAMHALL ENGINEERING & SURVEYING COMPANY. THIS PLAN IS BASED UPON AVAILABLE COUNTY INFORMATION.

PROPOSED LEGEND

- PROP. YARD HYDRANT
- PROP. WATER SERVICE VALVE
- PROP. WATER SERVICE TEE
- PROP. GAS VALVE

GENERAL NOTES

1. THIS PROJECT SHALL CONFORM TO THE REQUIREMENTS OF THE CITY OF WESTLAKE RULES AND REGULATIONS.
2. LOCATIONS FOR GAS AND WATER ARE DIAGRAMMATIC ONLY. SEE MEP PLANS FOR SPECIFIC SIZES AND DETAILS FOR BUILDING CONNECTIONS.
3. THE EXISTING WATER LINE LATERAL LOCATION IS DIAGRAMMATIC ONLY. CONTRACTOR MUST FIELD LOCATE AND VERIFY EXACT LOCATION FOR PROPOSED TEE CONNECTION.
4. CONTRACTOR SHALL CONTACT THE RESPECTIVE UTILITY OWNER OR PRIVATE COMPANY FOR SERVICE CONNECTION AND COORDINATION PRIOR TO STARTING THE WORK.
5. CONDUIT SIZES FOR UNDERGROUND ELECTRIC AND COMMUNICATION SHALL BE COORDINATED WITH THE MEP PLANS.
6. CONTRACTOR SHALL REPLACE SIDEWALK, CURB, AND ASPHALT ROADWAY IN KIND IF DAMAGED WHILE EXCAVATING UTILITY TRENCH.
7. CONTRACTOR SHALL REPLACE EXISTING TRAFFIC LIGHT LOOP IF DAMAGED DURING EXCAVATION OF DETROIT RD.
8. GAS AND ELECTRIC LINES SHALL BE RAN IN THE SAME TRENCH. MAINTAIN A MINIMUM HORIZONTAL SEPARATION OF 12" AND VERTICAL SEPARATION OF 18" FOR GAS AND ELECTRICAL CONDUIT.
9. IT IS THE RESPONSIBILITY OF THE CONTRACTOR TO FIELD LOCATE ANY AND ALL UTILITIES PRIOR TO PERFORMING ANY WORK. CONTACT THE UTILITIES PROTECTION SERVICE (1-800-362-2764) 48 HOURS IN ADVANCE OF WORK TO BE DONE NEAR ANY EXISTING UTILITY MAIN. NONMEMBERS MUST BE CONTACTED DIRECTLY.

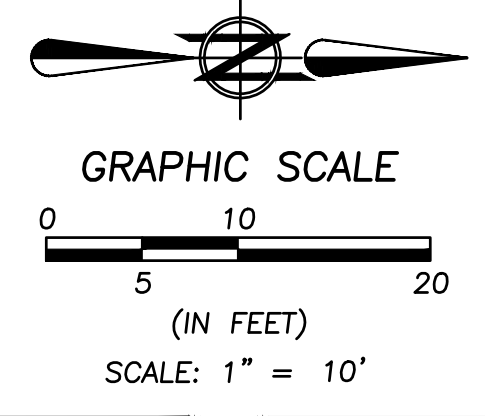

DATE:	BY:	DESCRIPTION:

DRAWN BY:
CAT

CHECKED BY:
WTB

BRAMHALL
ENGINEERING AND SURVEYING COMPANY
801 MOORE ROAD AVON, OHIO 44011
(440) 934 - 7878 (440) 934 - 7879 FAX

PREPARED FOR:
MCQA4 PROPERTIES LLC
27630 DETROIT RD
WESTLAKE, OH 4415

CAHOON NURSERY SITE DESIGN
MAINTENANCE BUILDING REPLACEMENT
UTILITY PLAN
CITY OF WESTLAKE, COUNTY OF CUYAHOGA, STATE OF OHIO

SHEET
C3.0

JOB NO.
20-5396B

J:\2025\988 Cahoon Nursery Site Design\DRAWINGS\Improvement Plans\Maintenance Building SITES.C3.0 Utility Plan.dwg, Plotter: Apr 25, 2026, - 10:38am