

BENCHMARK & CONTROL POINT

BENCHMARK & CONTROL POINT No. 1: MAGNETIC NAIL SET IN CONCRETE N: 656170.32 E: 2124597.15 ELEVATION = 678.58	BENCHMARK & CONTROL POINT No. 2: MAGNETIC NAIL SET IN CONCRETE N: 656013.25 E: 2124617.66 ELEVATION = 676.64
BENCHMARK & CONTROL POINT No. 3: MAGNETIC NAIL N: 656426.31 E: 2124644.57 ELEVATION = 677.04	BENCHMARK & CONTROL POINT No. 4: PIN FOUND N: 656239.07 E: 2124585.49 ELEVATION = 681.22

DATUM:
OHIO STATE PLANE COORDINATE SYSTEM
NORTH ZONE (3401)
HORIZONTAL DATUM: NAD 1983
VERTICAL DATUM: NAVD 1988

SURVEY NOTE:
A BOUNDARY SURVEY PURSUANT TO CHAPTER 4733-37 OF THE OHIO ADMINISTRATIVE CODE HAS NOT BEEN PERFORMED BY BRAMHALL ENGINEERING & SURVEYING COMPANY. THIS PLAN IS BASED UPON AVAILABLE COUNTY INFORMATION.

HATCH LEGEND

	PROP. BUILDING
	PROP. CONCRETE

GENERAL NOTES

- CONTRACTOR SHALL REPLACE CURB IN KIND IF DAMAGED WHILE REMOVING EXISTING CONCRETE WALK.
- ALL SITE WORK SHALL CONFORM TO O.D.O.T AND CITY OF WESTLAKE STANDARD CONSTRUCTION DRAWINGS.
- CONTRACTOR MUST SECURE ALL NECESSARY PERMITS PRIOR TO STARTING WORK.
- IF THE CONTRACTOR, IN THE COURSE OF THE WORK, FINDS ANY DISCREPANCIES BETWEEN THE PLANS AND THE PHYSICAL CONDITIONS OF THE SITE, OR ANY ERRORS OR OMISSIONS IN THE PLANS OR IN THE LAYOUT AS GIVEN BY THE ENGINEER, IT SHALL BE HIS DUTY TO IMMEDIATELY INFORM THE ENGINEER, IN WRITING, AND THE ENGINEER WILL PROMPTLY VERIFY THE SAME. ANY WORK DONE AFTER SUCH A DISCOVERY, UNTIL AUTHORIZED, WILL BE AT THE CONTRACTOR'S RISK.
- ALL CONSTRUCTION MATERIALS AND WORKMANSHIP SHALL BE IN ACCORDANCE TO THE STATE AND LOCAL GOVERNMENT AGENCY LATEST CONSTRUCTION SPECIFICATIONS AND DETAILS.
- THE CONTRACTOR SHALL MAINTAIN THE SITE IN A MANNER SO THAT WORKMEN AND THE PUBLIC SHALL BE PROTECTED FROM INJURY, AND ADJOINING PROPERTY BOTH PRIVATE & PUBLIC PROTECTED FROM DAMAGE.

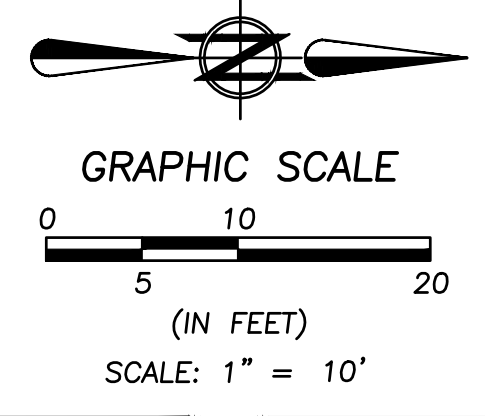

DATE:	BY:	DESCRIPTION:

DRAWN BY:
CAT

CHECKED BY:
WTB

BRAMHALL
ENGINEERING AND SURVEYING COMPANY
801 MOORE ROAD AVON, OHIO 44011
(440) 934 - 7878 (440) 934 - 7879 FAX

PREPARED FOR:
MCQA4 PROPERTIES LLC
27630 DETROIT RD
WESTLAKE, OH 4415

CAHOON NURSERY SITE DESIGN
MAINTENANCE BUILDING REPLACEMENT
SITE PLAN
CITY OF WESTLAKE, COUNTY OF CUYAHOGA, STATE OF OHIO

SHEET
C2.1
JOB NO.
20-5396B

J:\2025\888 Cahoon Nursery Site Design\DRAWINGS\Improvement Plans\Maintenance Building SITES\2.1 Site Plan.dwg, Plotted: Apr 29, 2026 - 10:23am