

**BENCHMARK & CONTROL POINT**

<b>BENCHMARK &amp; CONTROL POINT No. 1:</b> MAGNETIC NAIL SET IN CONCRETE N: 656170.32 E: 2124597.15 ELEVATION = 678.58	<b>BENCHMARK &amp; CONTROL POINT No. 2:</b> MAGNETIC NAIL SET IN CONCRETE N: 656013.25 E: 2124617.66 ELEVATION = 676.64
<b>BENCHMARK &amp; CONTROL POINT No. 3:</b> MAGNETIC NAIL N: 656426.31 E: 2124644.57 ELEVATION = 677.04	<b>BENCHMARK &amp; CONTROL POINT No. 4:</b> PIN FOUND N: 656239.07 E: 2124585.49 ELEVATION = 681.22

**DATUM:**  
OHIO STATE PLANE COORDINATE SYSTEM  
NORTH ZONE (3401)  
HORIZONTAL DATUM: NAD 1983  
VERTICAL DATUM: NAVD 1988

**SURVEY NOTE:**

A BOUNDARY SURVEY PURSUANT TO CHAPTER 4733-37 OF THE OHIO ADMINISTRATIVE CODE HAS NOT BEEN PERFORMED BY BRAMHALL ENGINEERING & SURVEYING COMPANY. THIS PLAN IS BASED UPON AVAILABLE COUNTY INFORMATION.

**HATCH LEGEND**

	EX. GRAVEL
	EX. BUILDING
	EX. FEMA FLOODWAY

**GENERAL NOTES**

- IT IS THE RESPONSIBILITY OF THE CONTRACTOR TO FIELD LOCATE ANY AND ALL UTILITIES PRIOR TO PERFORMING ANY WORK. CONTACT THE UTILITIES PROTECTION SERVICE (1-800-362-2764) 48 HOURS IN ADVANCE OF WORK TO BE DONE NEAR ANY EXISTING UTILITY MAIN. NONMEMBERS MUST BE CONTACTED DIRECTLY.
- THE CONTRACTOR SHALL CAREFULLY PRESERVE BENCHMARKS, PROPERTY CORNERS, REFERENCE POINTS, AND STAKES.
- EXISTING PUBLIC UTILITIES ARE SHOWN PER AVAILABLE RECORD PLANS. CONTRACTOR SHALL FIELD VERIFY LOCATIONS AND DEPTHS PRIOR TO STARTING CONSTRUCTION.
- CONTRACTOR SHALL BE RESPONSIBLE TO COORDINATE TREE REMOVALS WHERE NECESSARY.
- EXISTING CONDITIONS PLAN IS BASED ON THE ALTA NSPS LAND TITLE SURVEY DATED FEBRUARY 16TH 2024 PREPARED BY RIVERSTONE. THE ADJACENT PARCEL IMPROVEMENTS ARE BASED ON THE MCGREGOR PACE IMPROVEMENT PLANS DATED MARCH 5TH 2024 PREPARED BY MANNIK AND SMITH GROUP.

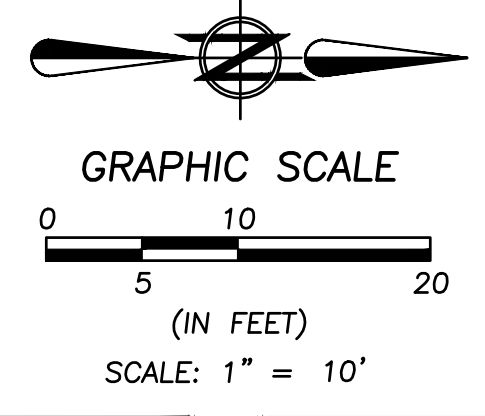

DATE:	BY:	DESCRIPTION:

**DRAWN BY:**  
CAT

**CHECKED BY:**  
WTB

**BRAMHALL**  
ENGINEERING AND SURVEYING COMPANY  
801 MOORE ROAD AVON, OHIO 44011  
(440) 934 - 7878 (440) 934 - 7879 FAX

PREPARED FOR:  
**MCQA4 PROPERTIES LLC**  
27630 DETROIT RD  
WESTLAKE, OH 4415

**CAHOON NURSERY SITE DESIGN**  
**MAINTENANCE BUILDING REPLACEMENT**  
**EXISTING CONDITIONS AND DEMO PLAN**  
CITY OF WESTLAKE, COUNTY OF CUYAHOGA, STATE OF OHIO

SHEET  
**C1.0**

JOB NO.  
20-5396B

J:\2025\988 Cahoon Nursery Site Design\DRAWINGS\Improvement Plans\MAINTENANCE BUILDING SITE\10 Existing Conditions.dwg, Plotter: Apr 29, 2026, 10:32am